



# ***SMART READER M4***

---

Reference Manual\_\_\_\_\_

**ENG**

*Version\_\_02.00.03 (September 2004)*

*© 2004 by TATTILE INTERNATIONAL LTD*

## Index

Smart Reader M4 Global View.....	5
Smart Reader M4 Mechanical Dimension.....	6
Smart Reader M4 silk-screen printings.....	7
Smart Reader M4 general characteristics.....	8
Smart Reader M4 interface connectors.....	10
Instructions for a right installation of TATTILE control equipment.....	16
Revision.....	18

---

*Questa pagina è intenzionalmente bianca.*

## Smart Reader M4 Global View

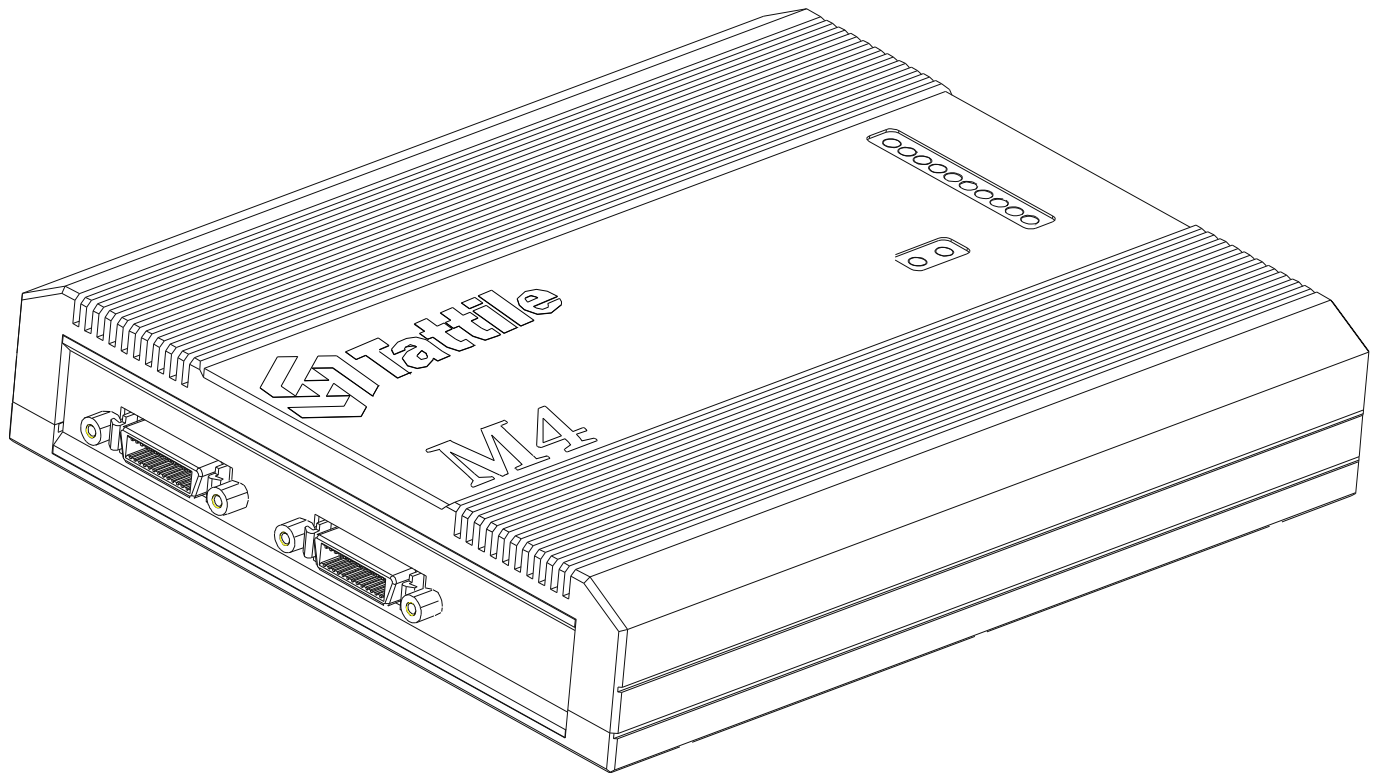

## Smart Reader M4 Mechanical Dimension

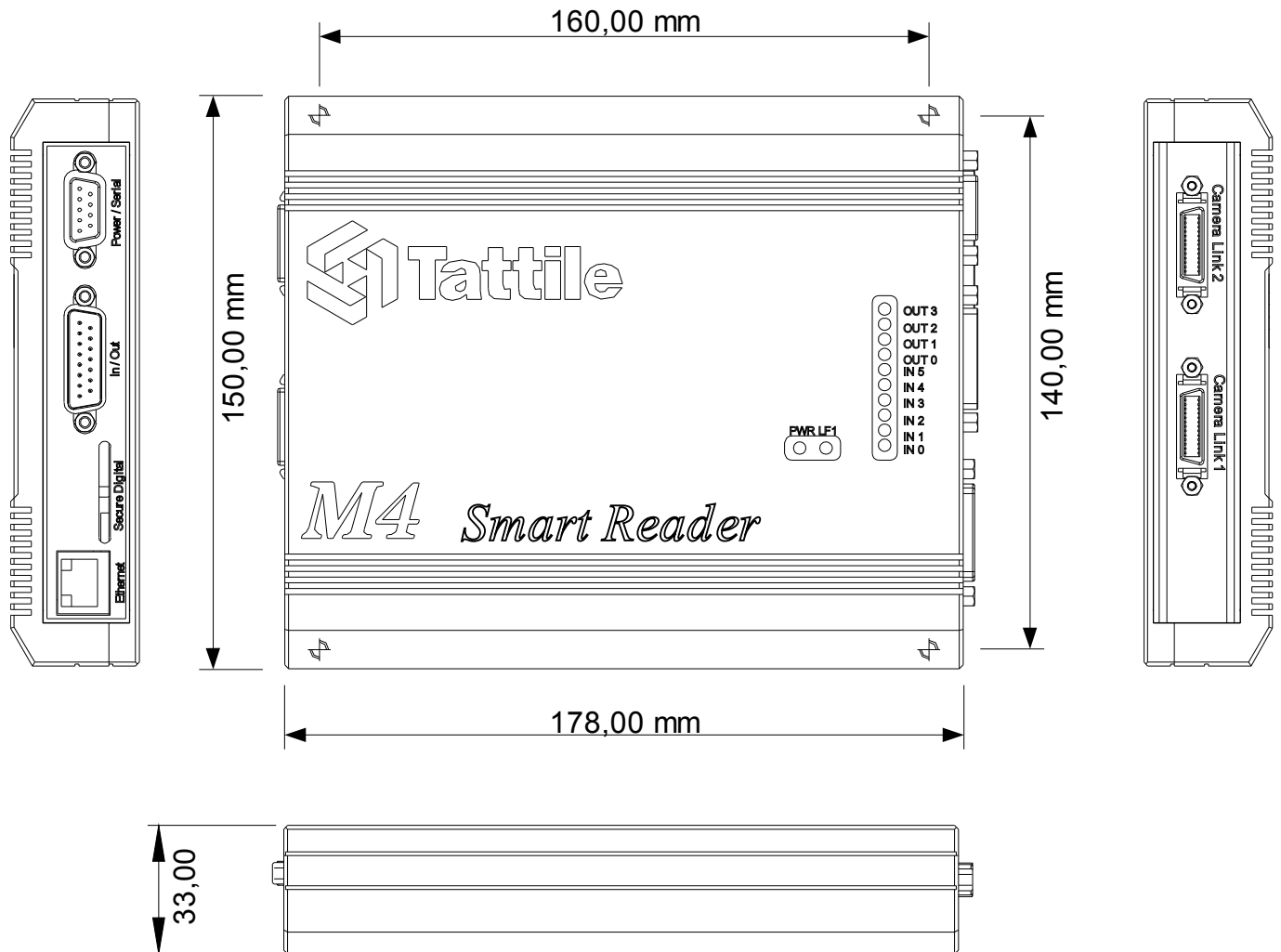

**Note:** to fix use M5 screws

## Smart Reader M4 silk-screen printings

### Frontal silk-screen printings

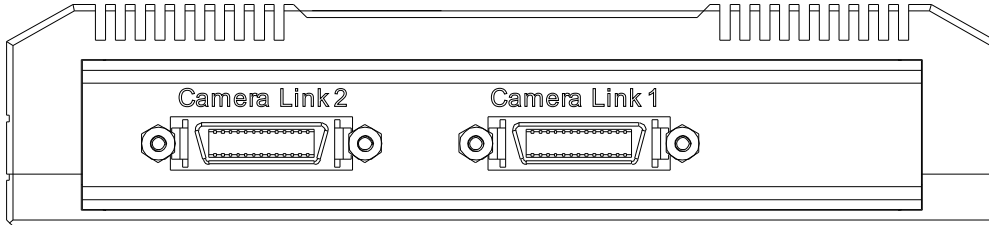

### Rear silk-screen printings

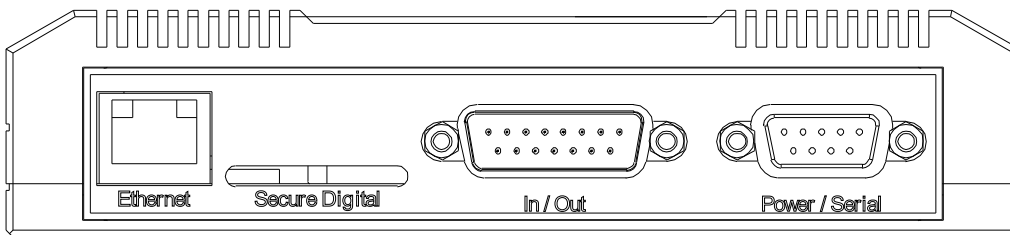

### Top silk-screen printings

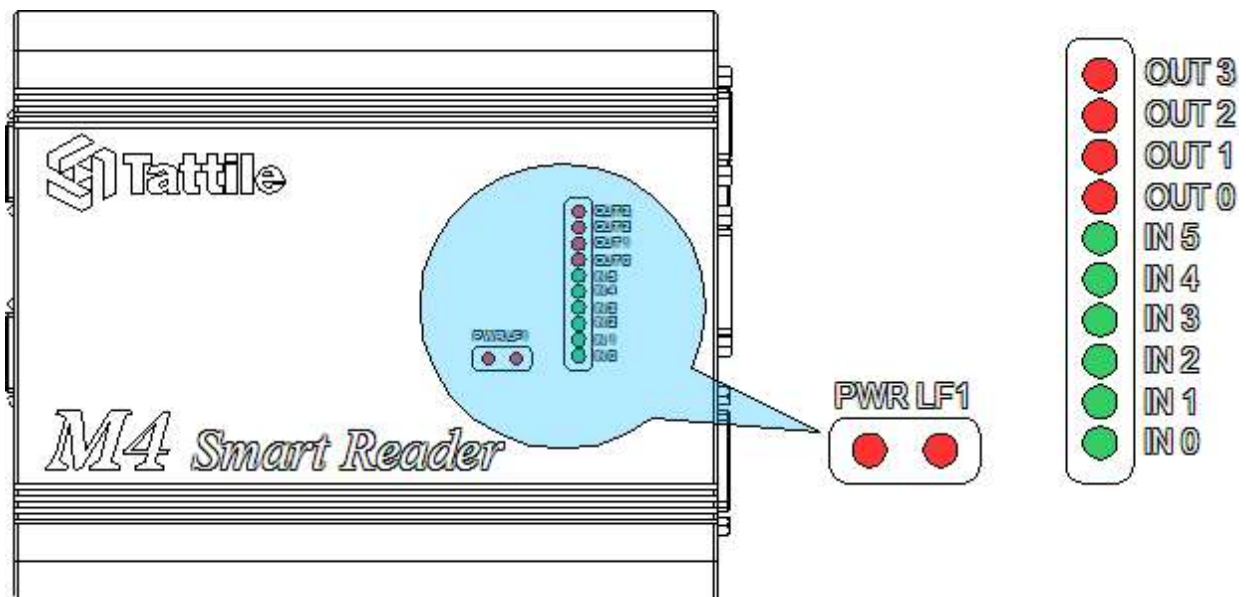

## Smart Reader M4 general characteristics

### **Smart Reader M4 characteristics**

- Power supply: 24Vdc.
- Power dissipation without loads: 7 W.
- Cameras: 2 Camera Link (BASE CONFIGURATION)  
1 Camera Link (FULL & MEDIUM CONFIGURATION).
- Camera digital input: 6 PNP inputs 24 Vdc 20 mA.
- Camera digital output: 4 PNP outputs 24 Vdc 500 mA, preserved to short-circuit.
- Camera strobe output: 2 Strobe output.
- Serial Port 232: 1 Serial Line RS-232.
- Serial Port 485: 1 Serial Line RS-485.
- Ethernet network: 1 ETHERNET line 10/100MB/s.
- Secure Digital: 1 Secure Digital Card slot.

### **Processing characteristics**

- Microprocessor: Intel XScale Technology
- Flash: 8-16-32 MByte
- SDRAM MICRO: 128/256 MByte 64bit 100MHz

### **Mechanical Characteristics**

- Smart Reader mechanical dimensions: 178 x 150 x 33 mm (LxHxW)
- Peso Smart Reader M4: 1200 g

### **Equipment**

- Smart Reader M4 central unit
- Reference Manual

### Work tensions

	<b>Description</b>	<b>Min</b>	<b>Typical</b>	<b>Max</b>	<b>Note</b>
<b>V<sub>CC</sub></b>	Voltage supply in the whole system	---	+24V±10%	---	Provide a stable supply, use at least a 50W power supply.
<b>V<sub>ENC</sub></b>	Encoder output voltage supply.	---	+5V (I <sub>MAX</sub> 800mA)	---	
<b>V<sub>I/O</sub></b>	Voltage supply in input output	+18V	+24V	+32V	Provide a stable supply

### Work conditions

<b>T<sub>op</sub></b>	Temperature of the surrounding environmental	0°C	---	50°	
<b>Humidity</b>	Dampness of the surrounding environmental	35%	---	85%	Without condense



**NOTE** : Don't connect the Smart Reader M4 power supplier to the I/O power supplier.

## Smart Reader M4 interface connectors

### Smart reader M4 camera link connections

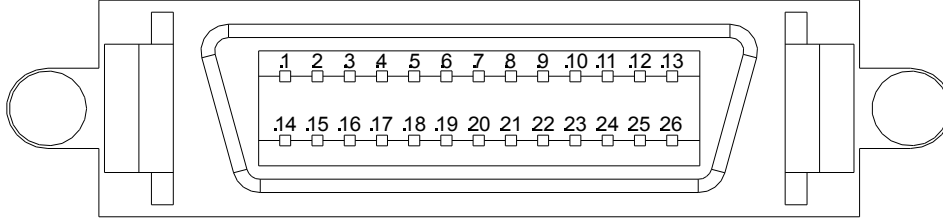

<b>FULL &amp; MEDIUM CONFIGURATION</b>				<b>BASE CONFIGURATION</b>		
<b>Camera Connector</b>	<b>SR M4 Connector</b>	<b>Channel Link Signal</b>	<b>Cable Name</b>	<b>Camera Connector</b>	<b>SR M4 Connector</b>	<b>Channel Link Signal</b>
1	1	Inner Shield	Inner Shield	1	1	Inner Shield
14	14	Inner Shield	Inner Shield	14	14	Inner Shield
2	25	Y0-	PAIR1-	2	25	X0-
15	12	Y0+	PAIR1+	15	12	X0+
3	24	Y1-	PAIR2-	3	24	X1-
16	11	Y1+	PAIR2+	16	11	X1+
4	23	Y2-	PAIR3-	4	23	X2-
17	10	Y2+	PAIR3+	17	10	X2+
5	22	Yclk-	PAIR4-	5	22	Xclk-
18	9	Yclk+	PAIR4+	18	9	Xclk+
6	21	Y3-	PAIR5-	6	21	X3-
19	8	Y3+	PAIR5+	19	8	X3+
7	20	100 Ohm	PAIR6+	7	20	SerTC+
20	7	Terminated	PAIR6-	20	7	SerTC-
8	19	Z0-	PAIR7-	8	19	SerTFG-
21	6	Z0+	PAIR7+	21	6	SerTFG+
9	18	Z1-	PAIR8-	9	18	CC1-
22	5	Z1+	PAIR8+	22	5	CC1+
10	17	Z2-	PAIR9+	10	17	CC2+
23	4	Z2+	PAIR9-	23	4	CC2-
11	16	Zclk-	PAIR10-	11	16	CC3-
24	3	Zclk+	PAIR10+	24	3	CC3+
12	15	Z3-	PAIR11+	12	15	CC4+
25	2	Z3+	PAIR11-	25	2	CC4-
13	13	Inner Shield	Inner Shield	13	13	Inner Shield
26	26	Inner Shield	Inner Shield	26	26	Inner Shield

**Input/Output interface connector**

**Input/Output PINOUT**  
15 Pin Male Front View

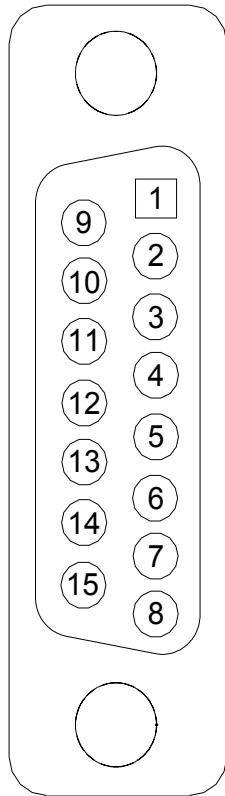

- |   |             |   |           |
|---|-------------|---|-----------|
| ① | INPUT 0     | ⑨ | $V_{I/O}$ |
| ② | INPUT 1     | ⑩ | STROBO 2  |
| ③ | INPUT 2     | ⑪ | STROBO 1  |
| ④ | INPUT 3     | ⑫ | OUTPUT 0  |
| ⑤ | INPUT 4     | ⑬ | OUTPUT 1  |
| ⑥ | INPUT 5     | ⑭ | OUTPUT 2  |
| ⑦ | $GND_{I/O}$ | ⑮ | OUTPUT 3  |
| ⑧ | $GND_{I/O}$ |   |           |

**Example of Input/Output connection**

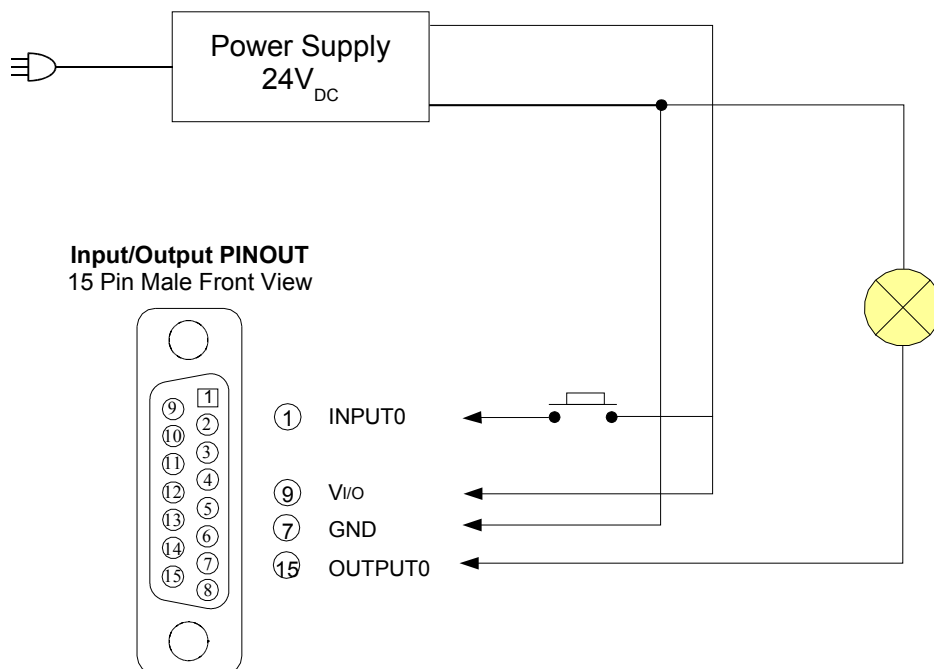

## Serial RS-232 and RS-485 Connection

RS-232 A, RS-485 e POWER  
PINOUT  
9 Pin Female  
Front View

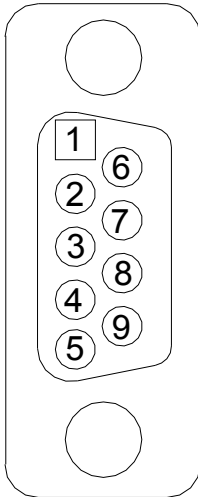

- |                 |                            |
|-----------------|----------------------------|
| ① A (RS-485 -)  | ⑥ Termination RS485        |
| ② TX (RS-232 A) | ⑦ GND <sub>Serialize</sub> |
| ③ RX (RS-232 A) | ⑧ GND <sub>Power</sub>     |
| ④ B (RS-485 +)  | ⑨ +Vcc                     |
| ⑤ <u>LINKER</u> |                            |

NOTE: Terminated with jumper between pin ① and ⑥

## Example of RS-232 and LINKER modality

Smart Reader  
RS-232 Serial Port  
9 Pin Male  
Welding View

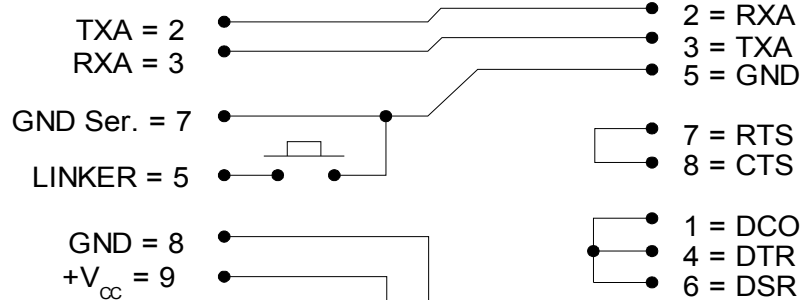
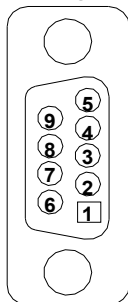

PC  
RS-232 Serial Port  
9 Pin Female  
Welding View

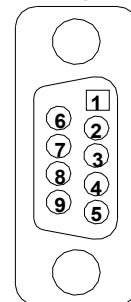

+24V GND  
Dedicated Power Supply  
+24 Volt 50W

### Example of RS-485 Serial Connection

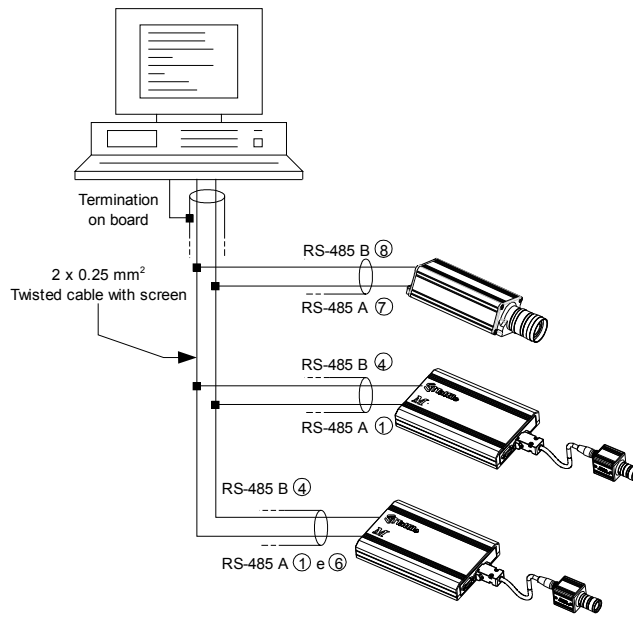

⚠ Terminated with jumper between pin ① and ⑥

### Example of Rs-485 Network

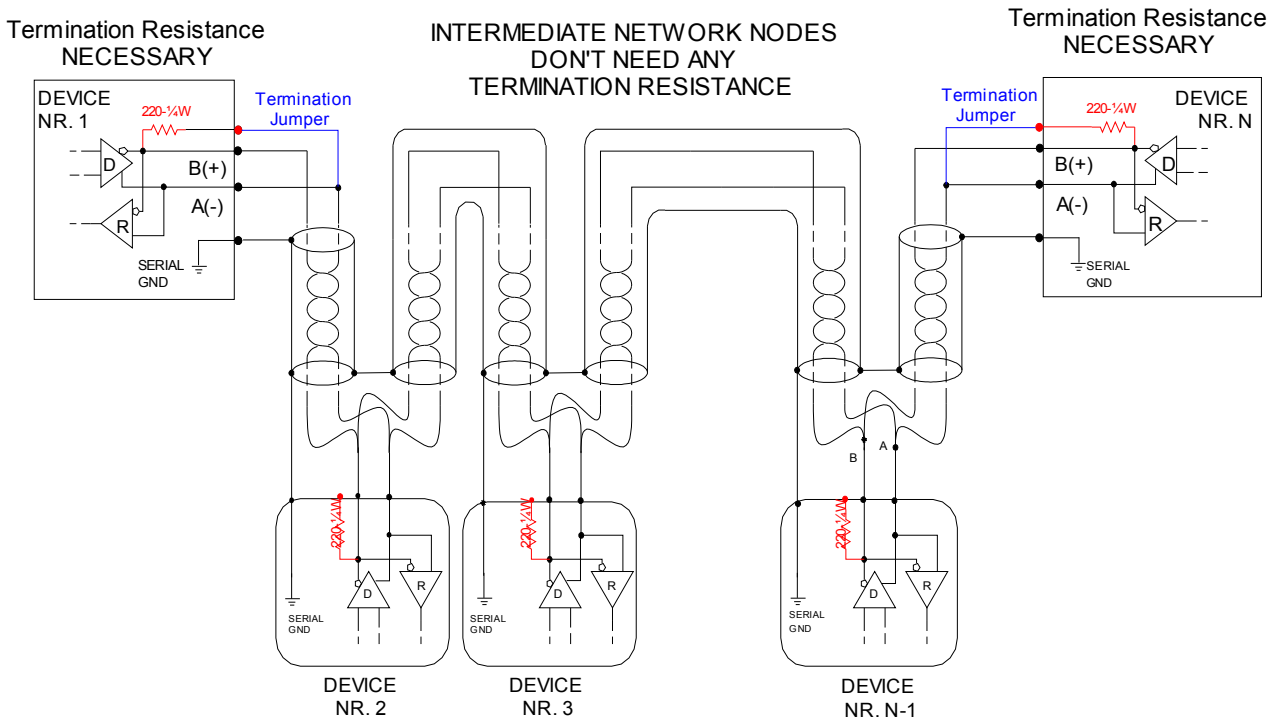

The internal termination resistance must be CONNECTED only on the first and the last devices of the chain.  
 All devices between the external node must not be terminated.  
 The shield of the cable must be linked to Serial GND of any devices of the chain.

## Ethernet Connector

### Ethernet RJ45 PINOUT

FEMALE 8 Pole

Front view

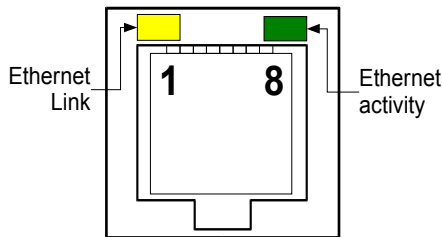

1	TX+ ( <i>Smart reader M4</i> )
2	TX- ( <i>Smart reader M4</i> )
3	RX+ ( <i>Smart reader M4</i> )
4	RX- ( <i>Smart reader M4</i> )
5,6,7,8	Signal Balance

## Ethernet connection cables

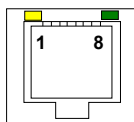
 Smart Reader  
Front View

Personal Computer

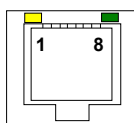

Cross-Over Cable CAT.5 STP/FTP

 Smart Reader  
Front View

10/100 Mbit Switch

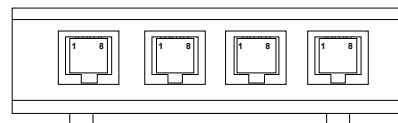

Direct Cable CAT.5 STP/FTP



Don't use HUB to connect.

**Example of connection towards a Personal Computer using a switch**

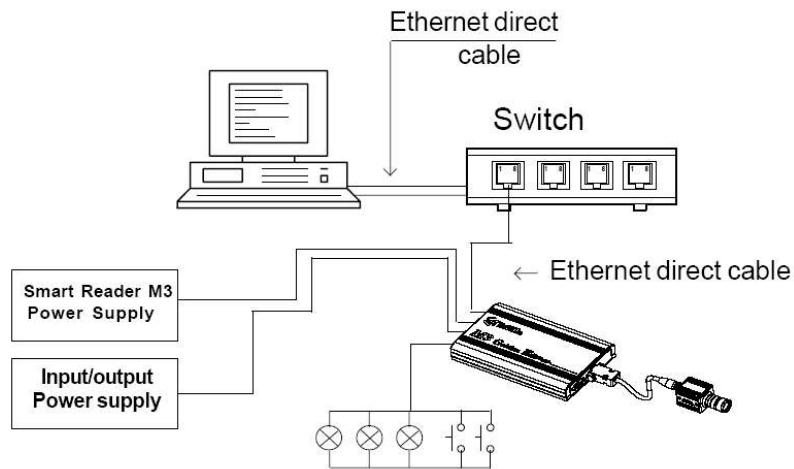

**Example of Smart reader M4 stand alone connection**

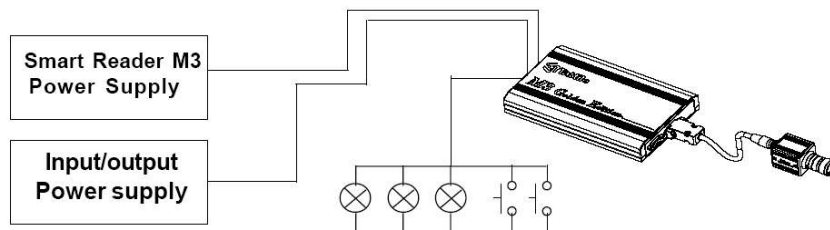

**Example of connection Smart Reader M4- PC**

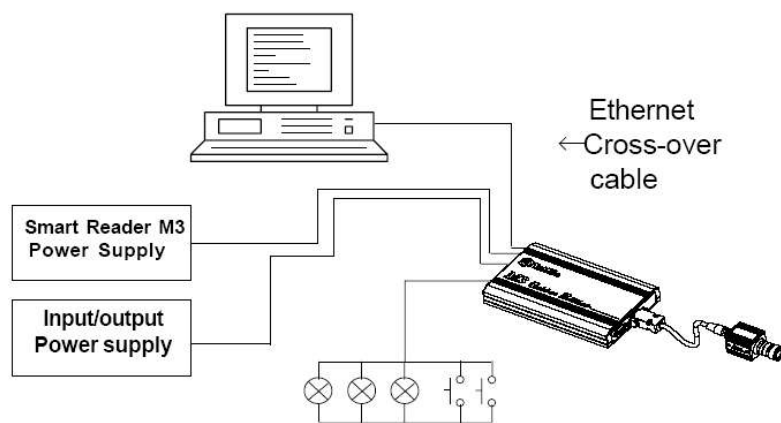

**NOTE:** When connecting the Smart Reader M4 directly to PC use the cross-over Ethernet cable.

## Instructions for a right installation of TATTILE control equipment

Good equipment operation is guaranteed only by respecting the instructions cited in this reference manual.

TATTILE declines all responsibility for anomalous equipment operation, installed with criteria not respecting these instructions.

- Fixing of the Smart Reader M4 must be done using only M5 screws applying 3Nm force.
- Smart Reader M4 cable courses must be kept separate from power cables.



- Pay attention to the various connections, especially in respect to the correct polarity of the power-supply cables.
- Supply the Smart Reader M4 with a dedicated power-supply (24VDC 12W) .



- The 24VDC voltage that powers inputs and outputs must never be taken from the same power source of the Smart Reader M4. The mass hasn't to be linked.
- The maximum length of the power supply cable is 2 mt. This cable must be screened and be not longer than necessary.
- Both the Smart Reader M4 analyser and separate camera must be fixed to structures well connected to the ground, mechanically stable and immune to vibration.



- Do not use HUB to connected Smart Reader M4 to ethernet network.
- Disconnect the remoted head only when the Smart Reader M4 is OFF.

## **Warning!**

***The warranty covering TATTILE equipment is invalidated when :***

1. The equipment has been opened or tampered with.
2. Faults due to incorrect connection of power or input/output circuits.
3. Faults due to overload or non-compliance with equipment's rated specifications.
4. Application act in conditions that do not comply with those specified for a correct installation.

---

**NOTE :** These conditions concern all equipment supplied with the system.

---

## Revision

*The Revision Index is reported below. The various revisions can contain additional information or corrections of printing errors.*

<b>Rev.</b>	<b>Date</b>	<b>Page</b>	<b>Description</b>	<b>Prepared</b>	<b>Checked</b>	<b>Approved</b>
02.00.00	19/01/04	All	First Release	Nicola G.	Fabio M.	Andrea S.
02.00.01	May 2004	11	Corrected the pin out of Input/Output connector. Changed position between STROBO 1 and STROBO 2.	Massimiliano D.	Fabio M.	Andrea S.
02.00.02	June 2004	11	Corrected the pin out of Input/Output connector. Changed position of OUTPUT0,1,2,3.	Massimiliano D.	Fabio M.	Andrea S.
02.00.03	September 2004	8,12,14,16	Corrected the number of digital inputs and outputs. Corrected the indication of + and – of RS-485. Corrected the pin out of RJ45. Added indication about not to use HUB.	Massimiliano D.	Mauro I.	Andrea S.