

TAPIX MBD 640 @60

Reference Manual

ENG

Preliminary

Version__02.00.00 (March 2004)

© 2003 by TATTLE INTERNATIONAL LTD

INDEX

Tapix MBD 640@60 Global View.....	5
Tapix MBD 640@60 Mechanical Dimensions.....	6
Tapix MBD 640@60 Silkscreen Printings.....	7
Tapix MBD 640@60 General Characteristics.....	8
Interface Connectors.....	10
Instructions for a right installation of TATTILE control equipment.....	12
Warranty.....	13
Revision.....	14

Preliminary

This page is intentionally left blank

Tapix MBD 640@60 Global View



Tapix MBD 640@60 Mechanical Dimensions

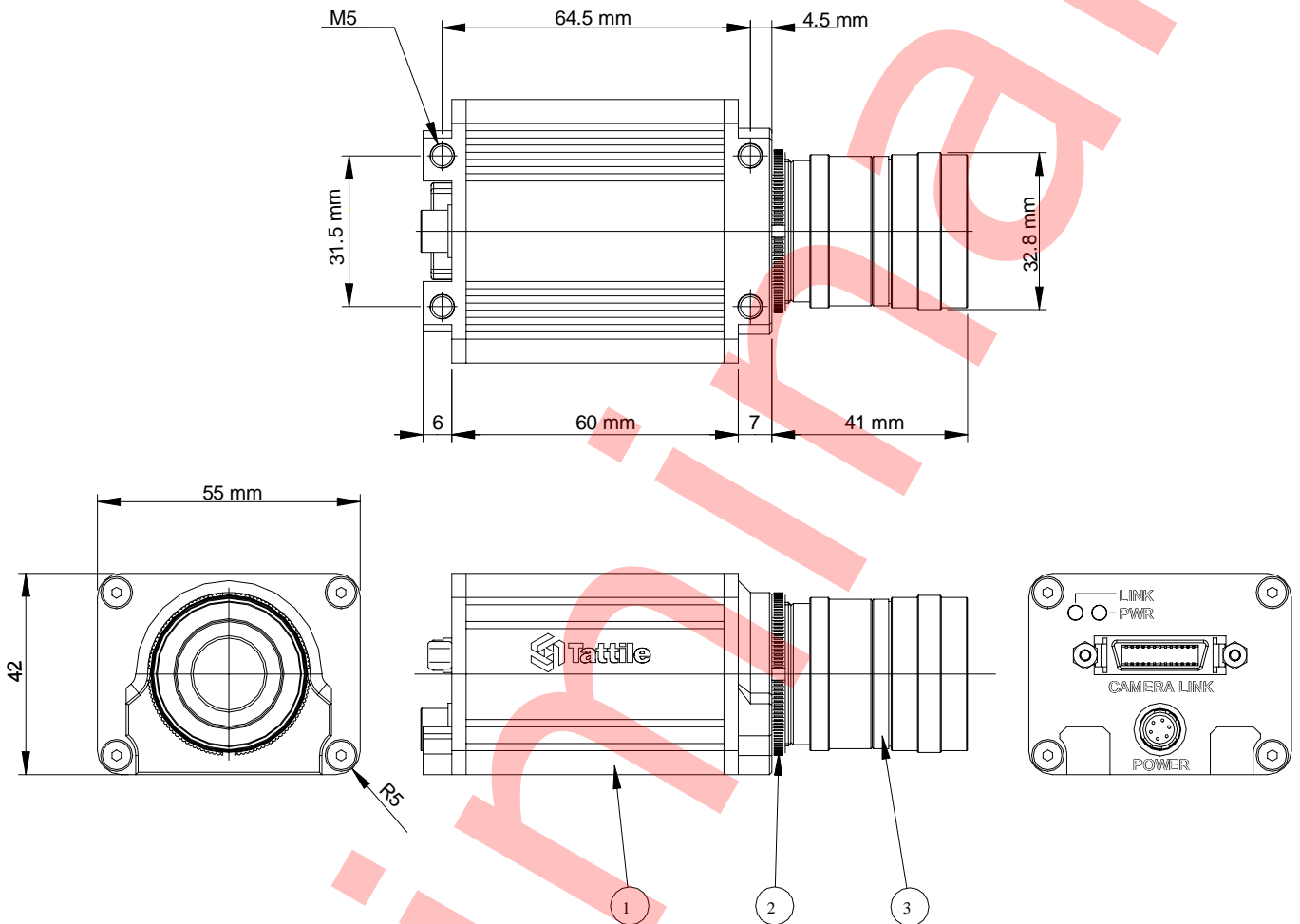

Tapix MBD 640@60 Silkscreen Printings

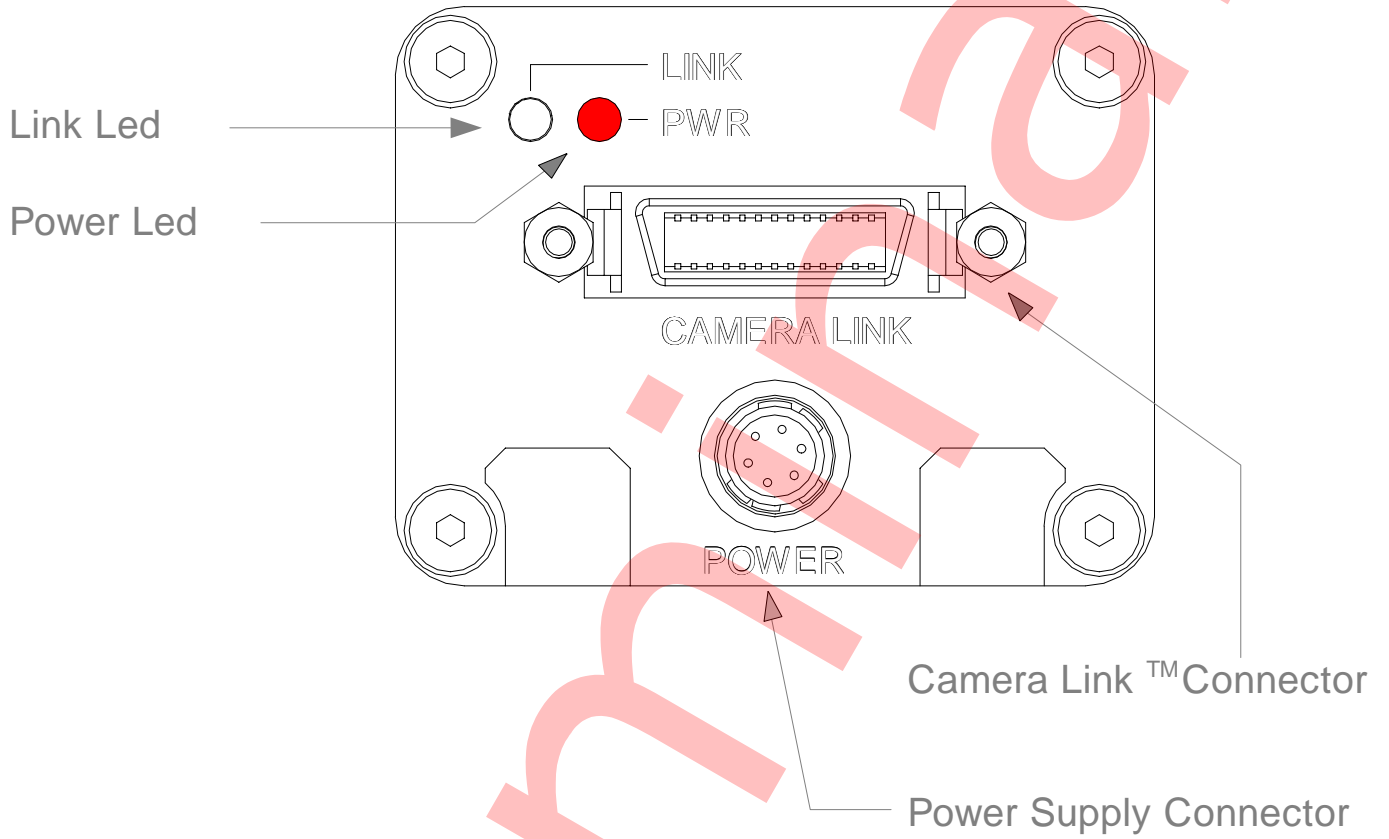

Tapix MBD 640@60 General Characteristics

Tapix MBD 640@60 Characteristics

- Power Supply: 24VDC \pm 10%
- CCD Characteristics: 640 x 480 pixels resolution , 7.4 μ m x 7.4 μ m size
- Communication Port: 1x40MHz data rate via Camera Link™ high speed serial interface

Processor:

- Microprocessor: ARM 40 Mhz
- Analogic/Digital Section: 1 A/D 10 bit/12 bit converter with Gain from 0 to 36dB
- Image Acquisition: Asynchronous (external Trigger with shutter to set by software)

Mechanical Dimensions

- Mechanical Dimensions: 73 x 42 x 55 mm (LxHxW)
- Weight: 220 g
- Conformity: **Conforms to CE standard.**

Standard Supply

- Tapix MBD 640@60 Camera.
- User Manual.
- Power Cable.

Work Tensions

	Description	Typical	Note
Vcc	Voltage supply in the whole system	+24 V	Provide a stable supply \pm 10%
GND	Ground	0 V	

Operating Conditions

	Description	Min	Max	Note
T _{op}	Temperature of the surrounding environmental.	0°C	50° C	
Humidity	Dampness of the surrounding environmental.	35%	85%	Without condense.

CCD General Characteristics

CCD Sony ICX424AL B/W Specifications

<i>Parameters</i>	<i>Value</i>
Image Size	Diagonal 6mm Type 1/3
Number of Effective pixels	659 (H) x 494 (V) approx. 330K pixels
Total Number of Pixels	692 (H) x 504 (V) approx. 350K pixels
Chip Size	5.79mm (H) x 4.89mm (V)
Unit Cell Size	7.4µm (H) x 7.4µm (V)
Optical Black	H direction: front 2 pixels, rear 31 pixels V direction: front 8 pixels, rear 2 pixels
Number of Dummy Bits	Horizontal 16 Vertical 5
Horizontal Drive Frequency	24.54 Mhz
Horizontal Register	5.0V drive
Package	16 pin DIP (Plastic)
Substrate Material	Silicon

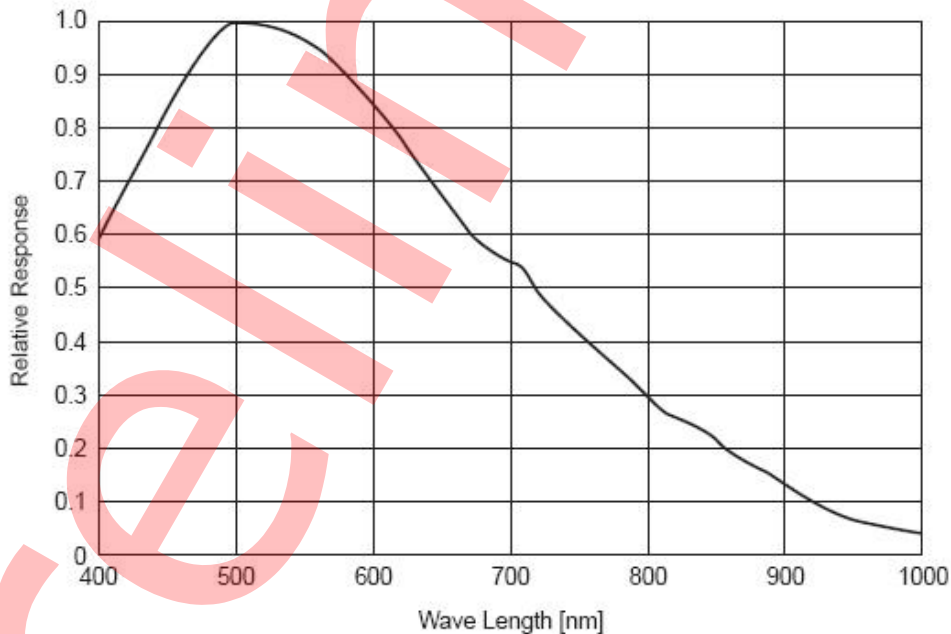

Spectral Sensitivity Characteristics

Interface Connectors

Power Connector

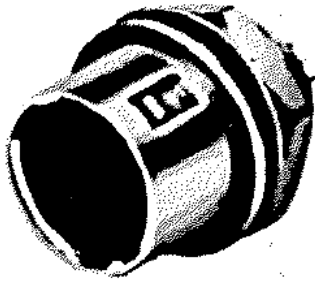

Hirose Hr10-7R-6S

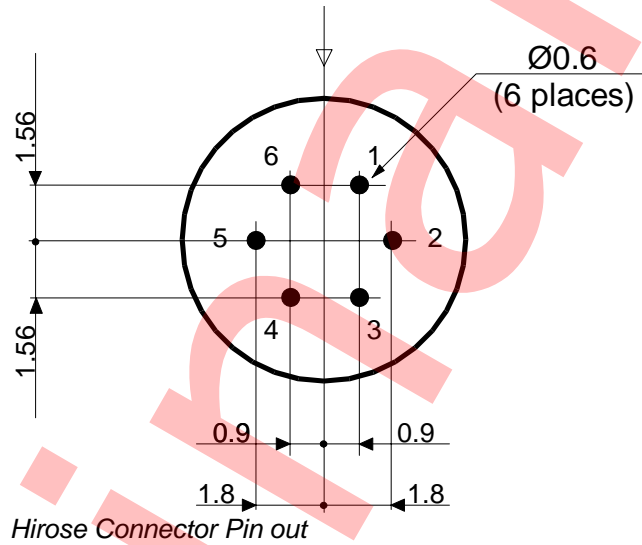

PIN	Description
1	+ Vcc
2	+Vcc
3	NOT CONNECTED
4	GND
5	GND
6	NOT CONNECTED

Camera Link™ Connector

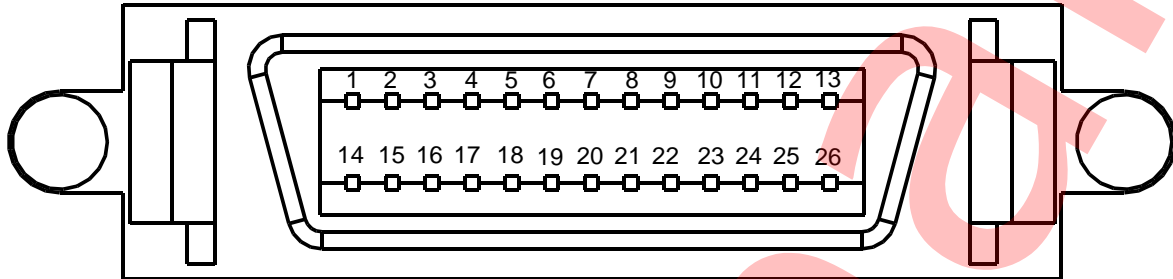

<i>Pin</i>	<i>Description</i>	<i>Pin</i>	<i>Description</i>
1	Logic Gnd via 0 ohm resistor	14	Logic Gnd via 0 ohm resistor
2	X0-	15	X0+
3	X1-	16	X1+
4	X2-	17	X2+
5	Xclk-	18	Xclk+
6	X3-	19	X3+
7	SERTC+	20	SERTC-
8	SERTFG-	21	SERTFG+
9	CC1-	22	CC1+
10	CC2+	23	CC2-
11	CC3-	24	CC3+
12	CC4+	25	CC4-
13	Logic Gnd via 0 ohm resistor	26	Logic Gnd via 0 ohm resistor

Instructions for a right installation of TATTILE control equipment

Good equipment operation is guaranteed only by respecting the instructions cited in this reference manual. TATTILE declines all responsibility for anomalous equipment operation, installed with criteria not respecting these instructions.

- Mounting of the Tapix MBD 640@60 must be done using only M5 screws applying 3Nm torque.
- Tapix MBD 640@60 cable courses must be kept separate from power cables.



- Pay attention to the various connections, especially in respect to the correct polarity of the power-supply cables.
- Supply the Tapix MBD 640@60 with a dedicated power supply (24V-12W).



- The 24VDC voltage that powers inputs and outputs must never be taken from the same power source of the Tapix MBD 640@60 and above all the mass must be split (negative pole).
- The maximum length of the power supply cable is 2 mt. This cable must be screened and not be longer than necessary.
- Tapix MBD 640@60 must be fixed to structures well connected to the ground, mechanically stable and immune to vibration.

Warranty

The warranty covering TATTLE equipment is invalidated when:

1. The equipment has been opened or tampered with.
2. Faults have been detected that are due to incorrect connection of the power or input/output circuits.
3. Faults are due to overload or non-compliance with equipment's rated specifications.
4. Application conducted in conditions that do not comply with those specified for a correct installation.



Note: These conditions apply to all equipment supplied with the system.

Revision

The Revision Index is reported below. The various revisions can contain additional information or corrections of printing errors.

Rev.	Date	Page	Description	Prepared	Checked	Approved
02.00.00	March 2004	All	First Release	Nicola G.	Massimiliano D.	Andrea S.